

THE INFORMATION CONTAINED IN THIS DRAWING IS THE SOLE PROPERTY OF DEL SMITH MANUFACTURING. ANY REPRODUCTION IN PART OR WHOLE WITHOUT THE WRITTEN PERMISSION OF DEL SMITH MANUFACTURING IS PROHIBITED.

## Request For a Quote

*Note: In order for us to respond as quickly as possible please, fill out the applicable information and fax it back to us. Our fax number is 323-265-3233.*

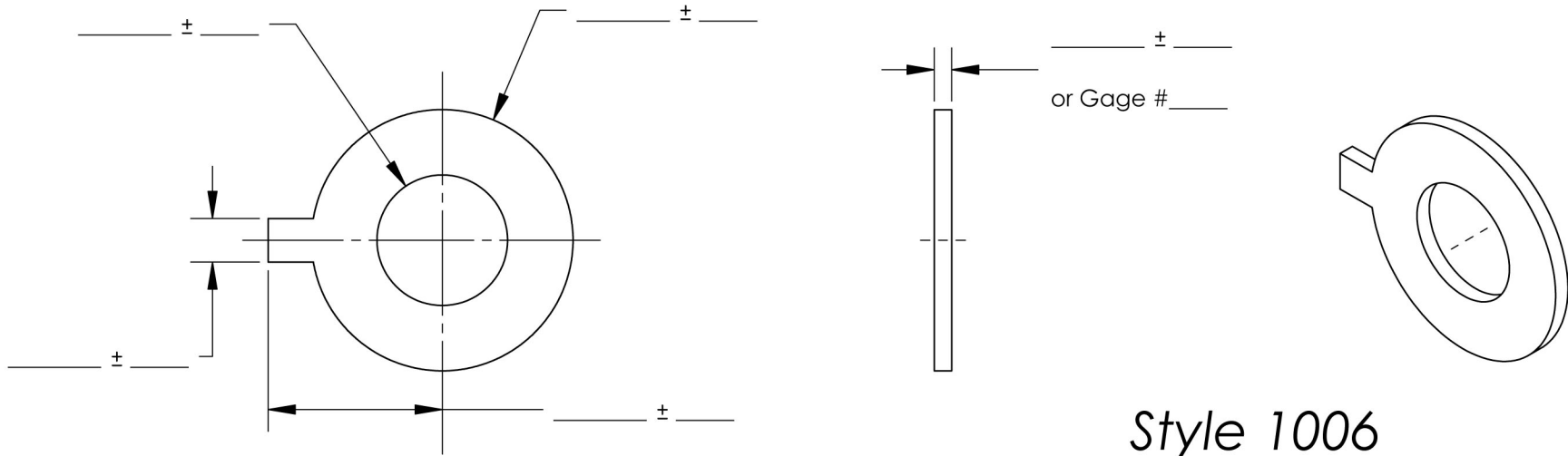

*Style 1006*

### Specifications

Quantity \_\_\_\_\_

Material \_\_\_\_\_

cert req'd YES NO (circle one)

Heat Treat \_\_\_\_\_

cert req'd YES NO (circle one)

Plating \_\_\_\_\_

cert req'd YES NO (circle one)

Other \_\_\_\_\_

### Your Information

Company \_\_\_\_\_

Contact \_\_\_\_\_

Telephone (\_\_\_\_) \_\_\_\_ - \_\_\_\_ x \_\_\_\_

Fax (\_\_\_\_) \_\_\_\_ - \_\_\_\_

### Previous Job History

(if this is repeat order)

Last Ordered on \_\_/\_\_/\_\_

Your last PO # \_\_\_\_\_

Our Invoice # \_\_\_\_\_

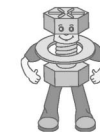

Mr. Washerman

### **Mr Washerman**

1432 Chico ave. S. El Monte CA 91733  
tel. 323-265-1205 fax 323-265-3233  
www.mrwasherman.com

1006 Washer